



SYSTEM PLATFORMS

BACKPLANES



CABINETS

COMPONENTS

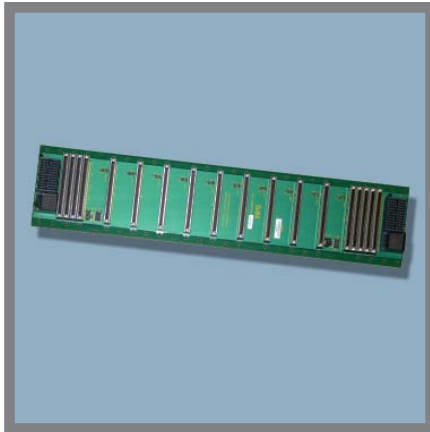

ACCESSORIES

SIMULATION SERVICES

MicroTCA: Products and Services

Elma Electronic

ABOUT ELMA

Founded in 1962, Elma is an industry innovator in the design and manufacture of electronic enclosures and passive electronic components. Elma enjoys a leading position in the VME/VME64x, VXI, VXS, PXI, cPCI, ATCA, MicroTCA and Rugged COTS packaging markets.

Based in Wetzikon, Switzerland and Fremont, California, Elma is a global leader in electronic enclosures and components. The company has facilities and representatives in over 40 countries. Elma has a broad base of customers in diverse industries such as telecommunications, industrial control, medical electronics, military and defense.

Elma strives to provide products superior in quality, reliability, performance, and consistently presents new, innovative designs to the market. Elma's product line encompasses well over 16,000 parts, including enclosures, cabinets, high quality switches, LED arrays, knobs and much more. Elma also offers design and integration services backed by responsive and knowledgeable technical support. Elma's leading quality level is reached through training of all employees and following of systematic procedures per ISO 9001 standards to which Elma has been registered.

CUSTOM SOLUTIONS

Customization is the standard at Elma Electronic. With an extensive offering of modular products as a foundation, Elma is able to leverage existing solutions and proven design concepts to meet any custom application. This approach ensures that Elma will provide a quality, compliant solution with significantly reduced lead time, cost and risk.

Elma leads the industry in modifying standard ATCA and MicroTCA backplanes and chassis to meet customer's exact needs.

TECHNICAL CAPABILITIES

- Agency Certification
- Verification Testing
- EMC Testing
- Thermal Testing
- System Integration
- Simulation/Characterization

WHY CHOOSE ELMA

Flexibility

Elma tailors solutions to individual applications to ensure fast and cost-effective results.

Experience

Extensive practical experience in packaging electronic systems is used to minimize the time taken to develop new customized solutions without compromising system performance or reliability.

Compatibility

Because the two key electromechanical components - enclosures and backplanes - are made in-house, Elma guarantees compatibility, consistency and reliability.

Global Resources

With manufacturing in Europe, Asia and the USA, customers benefit from local service backed by global resources.

ELMA PRODUCT DIVISIONS

Enclosures & Components



Backplanes



System Platforms



Switches, Knobs & LEDs



Cabinets



MicroTCA Design Technology

ADVANTAGES OF MicroTCA

- Complementary to ATCA
- Support applications where ATCA is not ideal
- Heavy emphasis on reduced start-up costs
- Leverage use of defined AdvancedMC Module standard
- AdvancedMC's directly connect to the backplane
- Smaller physical box size for size constrained applications
- Scalable reliability (relaxed system management complexity)
- Modular and serviceable (front-loadable, hot-swap)
- Rugged support for Outside Plant systems
- Universal platform (vs. proprietary design)

THERMAL SIMULATIONS

Elma has performed extensive thermal simulation studies to optimize the design of its comprehensive MicroTCA packaging product line. It ranges from development systems to highly redundant systems to fully populated cabinet-level solutions.

Using the Computational Fluid Dynamics (CFD) modeling software Flotherm, Elma's engineers optimize air intake and exhaust openings, increase or decrease plenum space, locate baffles to vary slot openings and redirect air flow where required. Locating hot spots in the chassis, the designer can simulate various scenarios to rectify the situation and select the appropriate fans and components. Finally, the designer finds the ideal balance of cooling, EMC, audible noise, power, and other elements to meet or exceed the specifications and keep costs low.

Reference AdvancedMC modules according to MicroTCA specification are used by the Elma team. Any custom AdvancedMC module can be incorporated in the thermal simulation to verify and optimize your specific cooling requirements.

Elma's design philosophy embraces extensive use of thermal simulations that helps to perfect the design and reduce time to market. Our Validation Lab includes thermal, environmental, and EMC chambers and a wind tunnel to verify the results.

MODULAR DESIGN

Elma's unique modular MicroTCA solution allows a wide range of design options. The Elma solution is extrusion-based, with modular card guides allowing various slot counts, card heights, and component configurations. This greatly reduces the costs, lead-time, and risk of tailoring a configuration to a customer's specific needs. The card guide support plate allows the same chassis to contain both single width (75mm high) or double width (150mm high) modules. The Elma modular design also keeps prototyping costs low. When a project moves to higher volumes, Elma can switch from extrusions to stamped sheet metal.

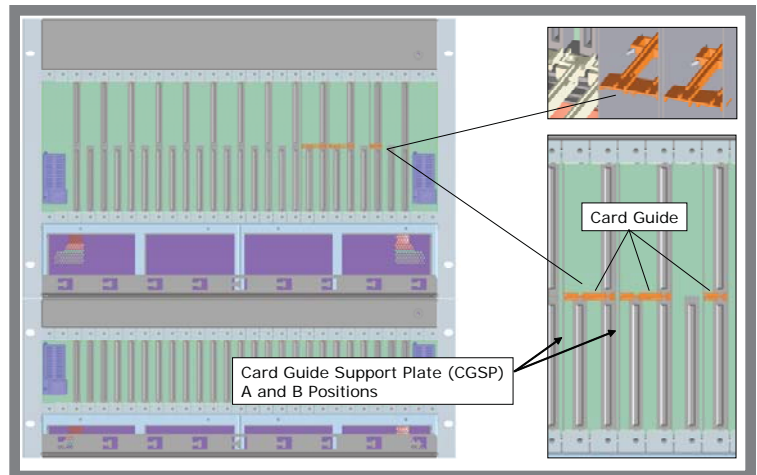
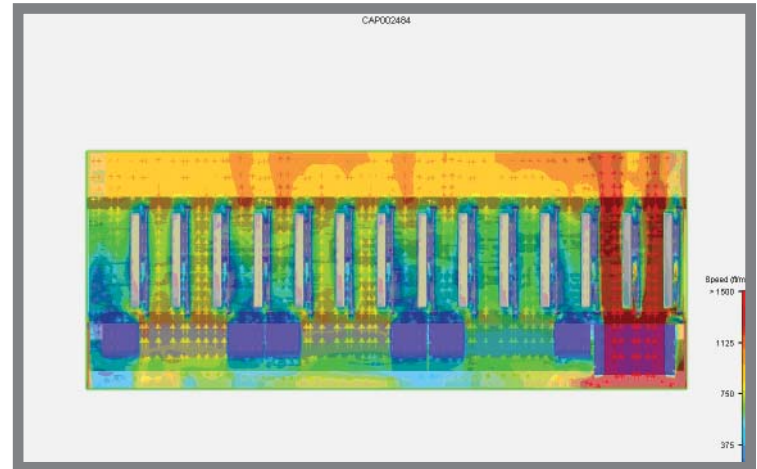
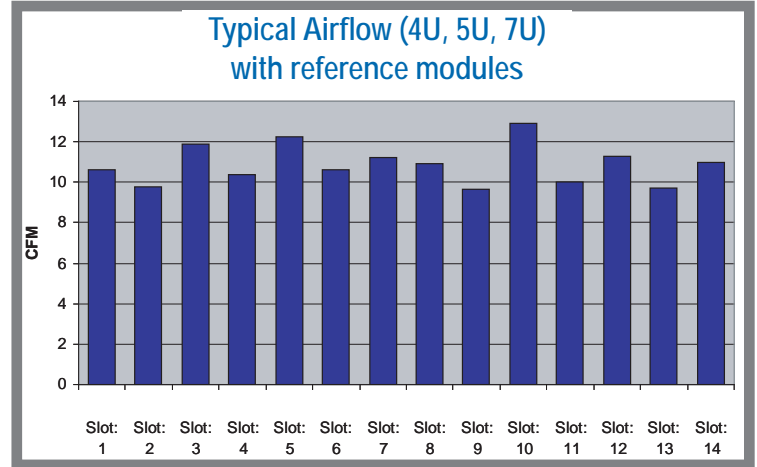
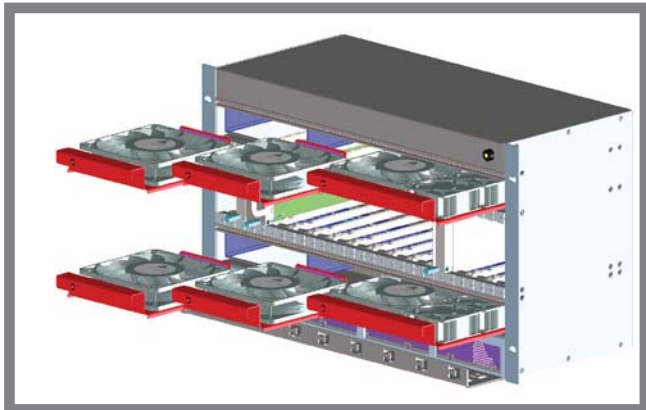

MicroTCA System Platforms



FEATURES

- Compliant to latest MicroTCA.0 specifications
- Modular design using tooled extrusions and card guides
- Allows various chassis configurations using standard building blocks
- Customization is faster, easier, and more cost-effective as design is built upon a proven modular platform
- Platforms can be assembled with a high degree of precision and meet tight design tolerances - modules plug in easily
- Accommodates various backplane configurations based on a combination of full-size (6HP), mid-size (4HP) and compact (3HP) modules without any impact to chassis mechanics
- Plastic card guides provide isolation between the modules and the chassis mechanics
- Extrusion approach will facilitate future ruggedization efforts of the modules' front panel
- Subsystem integration services are available



TYPE 11M MicroTCA SHELF

- 19" rackmount shelf
- 2.5U - 8U H x 84HP W x 299mm D
- Modular extrusion-based solution
- Shelves available for all module configurations
- Various backplane configurations
- Single or dual redundant fan trays in push only or push/pull configurations
- Removable air filter(s)
- Assembled and wired
- Optional cable tray
- Optional locking bars to secure modules in shelf
- Optimized via thermal simulation studies
- Customized versions available
- Order Number: 11MXXXXXX2VXXXX (see order key on page 12 for "X" options)



5U SHELF

Photo Coming Soon

6U SHELF



7U SHELF



8U SHELF



TYPE 32M MicroTCA PORTABLE TOWER

- 370mm H x 279mm W x 308 mm D
- Ideal for prototyping and demonstrations
- Modular extrusion-based solution
- Accepts various module configurations
- Allows both single and double modules in same chassis
- Pluggable fan tray with removable air filter
- Convenient handle makes it ideal for portability
- Assembled and wired
- Optional locking bars to secure modules in chassis
- Optimized via thermal simulation studies
- Customized versions available
- Order Number: 32M06ZK643VHXXXP (see order key on page 12 for "X" options)

MicroTCA System Platforms



TYPE 39M MicroTCA SHELF

- Various height, width, and depth configurations possible
- Sheet metal solution, ideal for high volume applications
- Accepts various module configurations
- Various backplane configurations
- Single or dual redundant fan trays in push only or push/pull configurations
- Removable air filter(s)
- Assembled and wired
- Optional locking bars to secure modules in chassis
- Optimized via thermal simulation studies
- See order key on page 12 for options

MicroTCA Backplanes

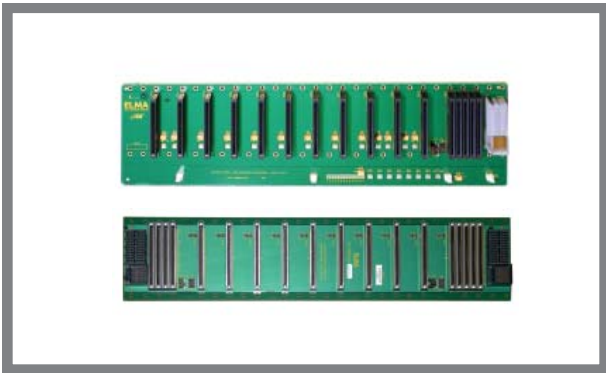

MicroTCA BACKPLANE

- Complies to PICMG MicroTCA.0 Rev. 1.0
- Compression-mount style connectors standard, Press-fit or surface-mount are optional
- Connectors for fan units and power input
- Slot-to-slot aggregate bandwidth of 5,000 Mbytes/sec
- Star Backplane
 - 12 AMC, 1 MCH, 1 power module (full size)
- Dual Star Backplane
 - 10 AMC, 2 MCH, 2 power modules (full size)
- Other versions available in various configurations
- Standard shelf management - MicroTCA Carrier Hub (MCH)
- Optimized via signal integrity studies
- Order Numbers: Star 69-14SK-12-1-1, Dual Star 69-12DL-10-2-2



MicroTCA CUBE BACKPLANE

- According to PICMG MicroTCA.0 Rev. 1.0
- Compression style connectors easily replaceable
- Star cube backplane
 - 6 AdvancedMCs, 1 MCH, 1 power module (all full size)
- 12-layer board
- Direct connections for storage protocols
- Pluggable connector for fan tray
- Order Number: 69-10DL-6-2-2

BACKPLANE SIGNAL INTEGRITY STUDIES

Elma Bustronic's signal integrity analysis and simulation services ensure efficient cost-effective design solutions that work superbly the first time, every time. And we continue to expand our technical resources with new high-speed measurement technology, interconnect model extraction, and software to support measurement-driven design. The simulations predict the characteristics of a custom design and eliminate "trial and error," resulting in faster turnaround and guaranteeing that our products meet or exceed your specifications.

Faster PCB designs are by nature more sophisticated and delicate. At higher clock speeds, the PCB demands cleaner signal transmission without compromising the stability of the system. This is where Signal Integrity engineering comes into play. Simply put, signal integrity studies the design of high-speed circuits that can accommodate cleaner signals passing through them.

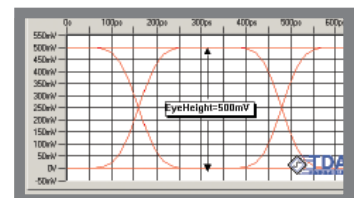

MicroSlim™ Shelf



FEATURES

- Compliant to latest MicroTCA.0 specifications
- Modular design using tooled extrusions and card guides
- Low profile, saves vertical rack space
- 1U version has mounting for up to 6 x AMC modules (single width/mid size)
- 1U version's 5 bays allow up to 10 mid sized/single width modules
- 3U version holds up to 12 AMC's
- 3U version offers 2 MCH, 2PM, 1 JSM, and 3 spare slots
- Redundant hot-swappable Cooling Units (CUs)
- J-TAG compatible with USB diagnostics port and speed control
- Platforms can be assembled with a high degree of precision and meet tight design tolerances - modules plug in easily
- Accommodates various backplane configurations based on a combination of full-size (6HP) and mid-size (4HP) modules without any impact to chassis mechanics
- Plastic-coated card guides provide isolation between the modules and the chassis mechanics
- Extended (back-to-back shelf) version coming soon
- Order Number:
 - 1U: 39M06SZK182HXXXXR (see order key on page 12 for "X" options)
 - 3U: 39M12SZL382HXXXXR (see order key on page 12 for "X" options)

The Elma MicroSlim™ Shelf offers optimized performance density. With side-to-side cooling and the modules placed horizontally, the MicroSlim™ Shelf subracks save vertical rack space. Cooling is maximized with densely packed Cooling Units in a redundant push/pull cooling configuration. Testing in the 1U version boasted a total of 96CFM @ .75 H₂O of cooling capacity with 8 x 20CFM fans. The heat dissipation of 36W per module ensures that even the densest AMC's are properly cooled. The MicroSlim™ Shelf also features separately removable and managed air filters. The IPMB-0 managed FRUs include speed control on the fans for noise reduction. Vertical Pico configurations are also available.

The backplane for the MicroSlim™ Shelf features compression-mount connectors. These offer increased reliability and superior (easier and more flexible) routing. If a connector is damaged in the field, it has two screws securing it in place that can be easily removed for replacing the connector. The backplanes have undergone signal integrity studies to optimize the performance.

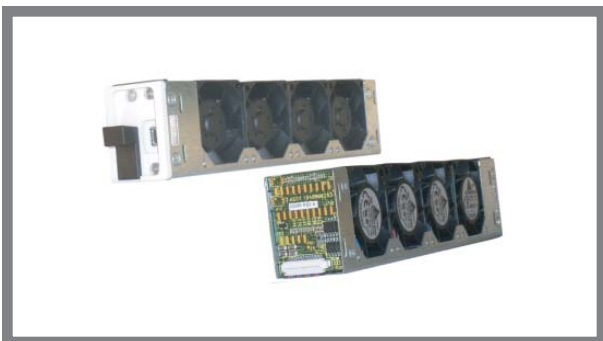

COOLING UNITS (1U Version)

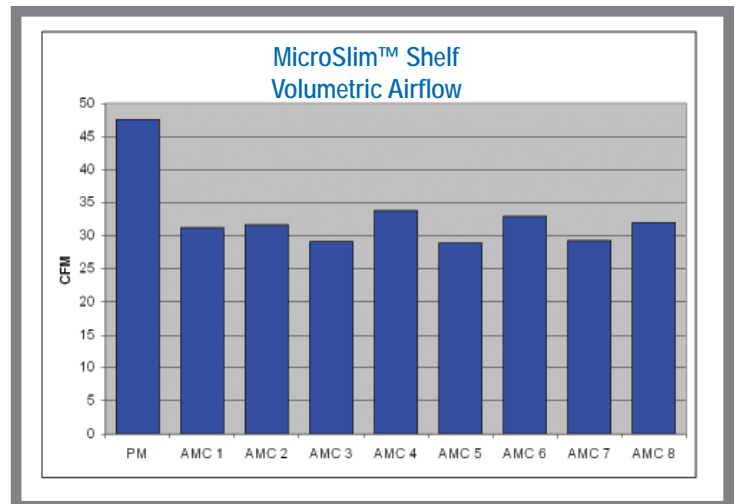

MicroTCA EcoBox System Platform



FEATURES

- Low-cost MicroTCA System Platform, rackmount or desktop
- One MCH and 5 single/full size AMC slots
- ATX power supply - 300W, 12V output
- IPMI Power Distribution Module integrated on the backplane
- Cooling unit with IPMI support on backplane
- Full compatibility with management section of MicroTCA specification
- Optional connection AMC1 to AMC3
- Tested with various industry-standard MCHs and AMCs
- Order Number: CAE026503

As a new and upcoming architecture, MicroTCA is currently too costly for some industrial and more cost-sensitive markets. One of the most expensive components of a MicroTCA system is the power module. Elma has created the new EcoBox to help alleviate these costs. We have separated the power management from the power module and integrated the management intelligence onto an active backplane.

The new system platform is fully compatible with the MicroTCA specifications. The EcoBox has been tested with various industry-standard MCHs and AMCs at Interoperability Workshop and in Elma's labs. The system platform uses a pluggable 300W, 12V-ATX power supply. However, the IPMI intelligence for voltage supply and control is located on the backplane. This includes +3.3 V, in-rush current control and over-current protection.

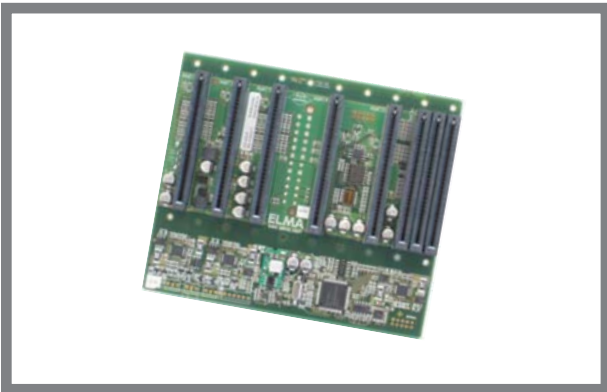

MicroTCA EcoBox ACTIVE BACKPLANE

- 1 MCH, Star topology
- 5 AMC slots, single width/full size
- Optimized High-Speed routing
- IPMI intelligence for voltage supply and control located on the active backplane
- Direct SATA/SAS connections and PCIe links
- Order Number: Consult Factory

MicroTCA EcoBox System Platform

Block Diagram

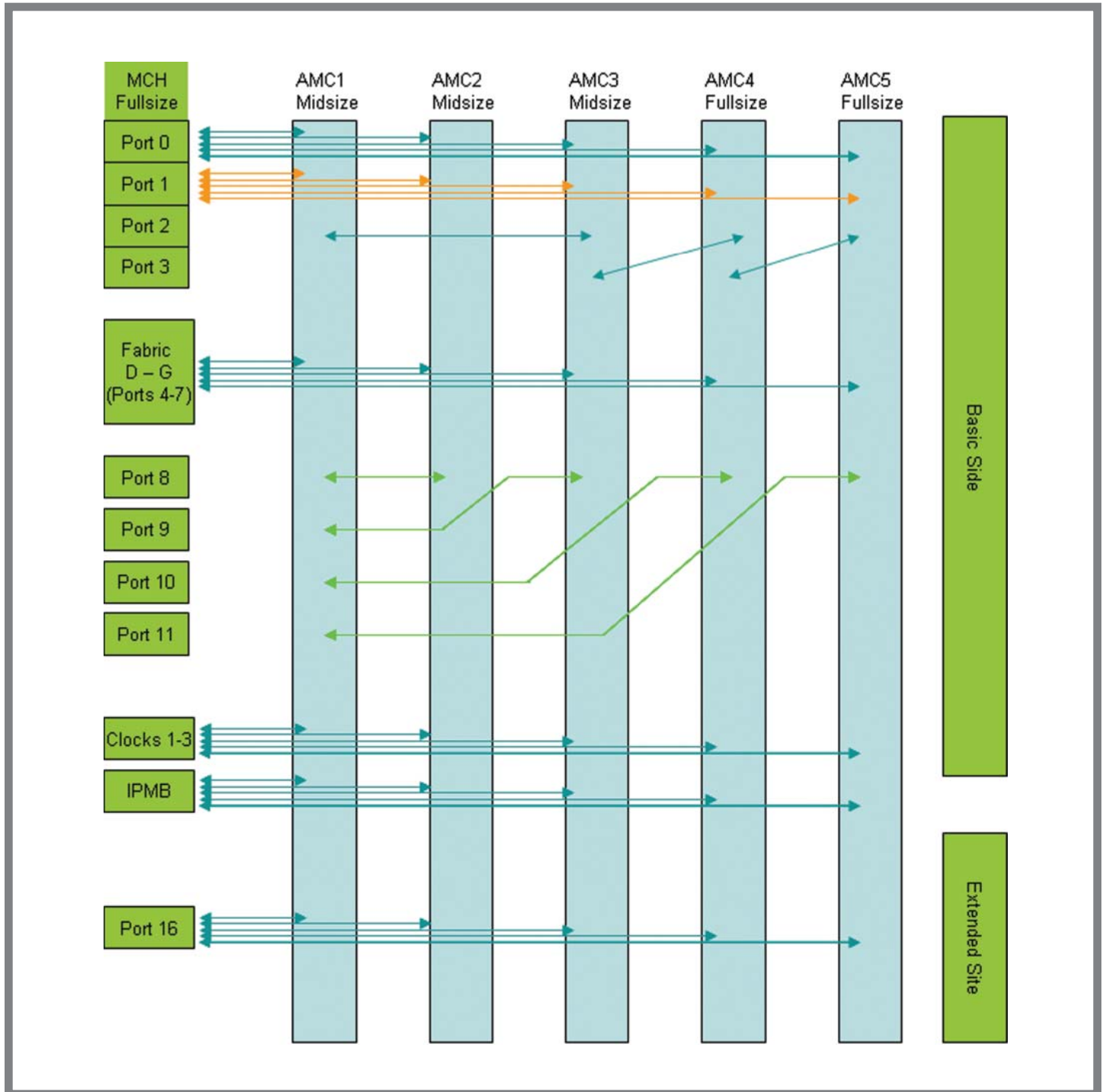

MicroTCA Rugged Products



Ruggedized MicroTCA ATR

- MicroTCA ATR Long Enclosure
- 6 AMC, 1 MCH, 1 PM slots
- Designed to ARINC 404A
- Structural integrity through milled front and rear panel
- Designed to meet MIL-STD 810 E
- Support for MCH Single Module - Full Size
- Support for single Power Module Full Size (6 HP)
- ELMA high performance EMMC Cooling Unit, honeycomb filter
- Ruggedized card guides secure cards in chassis

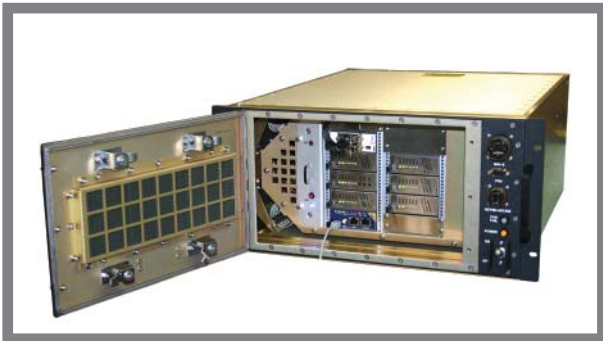

Ruggedized MicroTCA Rackmount

- Ruggedized MicroTCA COTS System Platform
- 6 AMC, 1 MCH, 1 PM (to 600W) slots
- 19" rackmount, horizontal mount
- Meets MIL-STD-810F, 167, 461D, and 901D
- Shock isolated card cage and device mounting
- Rugged chassis shells from thick aluminum sheets, extrusions, and die-castings. Joined by riveting, spot-welding, and stainless steel screws
- Front to rear evacuative cooling
- Removable fan tray features 1x (120mm x 120mm) fan and 2x (40mm x 40mm) fans, and finger guard
- Fan tray has ergonomic handle and LEDs for: voltage monitoring, fan fail and over temp
- Line filter, GND stud, shielded relay, IO panel, USB port, and fuse holder
- Temp: 0°C to 65°C operating temperature, Shock: 25Gs 11 ms

Elma's ruggedized MicroTCA solutions come in ATR and 19" rackmount versions. A modular design approach allows great flexibility in sizes and configurations. Elma performed verification testing on its ruggedized ATR (testing on rackmount version coming soon). The unit passed MIL-STD-810E for shock/vibration using only front panel clamps and specialized rugged card guides. Further protection can be incorporated with isolators/dampers and shock absorbers. The chassis also passed MIL-STD-461 for EMC. A full 35-page test report is available upon request. Versions will be available in forced air and conduction cooled formats. Elma's team is authoring key sections of the MicroTCA.1 and MicroTCA.2 specifications for Rugged MicroTCA.

MicroTCA Related Products



MicroTCA CARRIER HUBS (MCHs)

The MicroTCA Carrier Hub (MCH) v2.7 is designed to conform to the PICMG MicroTCA v1.0 specification. The CEN-MCHv2.7 serves as the logical and physical hub for delivering networking connectivity (base and fabric), management and clock for AdvancedMC-centric MicroTCA systems.

The main CEN-MCHv2.7 PCB (printed circuit board), MCH PCB 1, uses CorEdge Networks patent-pending technology to deliver base channel switching and AdvancedMC/MCH management in one chip.

MCH PCB 1 utilizes a MicroTCA Carrier Management Controller (CEN-MCMC) that is based on the CorEdge Networks ATCA/AdvancedMC Carrier IPM-C and ATCA IPMI Shelf Manager. The CEN-MCMC uses IPMI to manage local MicroTCA shelf elements (AdvancedMCs, power, cooling and MCHs). The CEN-MCMC links the MicroTCA-system to a System Manager via an Ethernet over LAN face plate interface and supports a mini-USB interface for direct serial console access and a RJ45 interface to manage a Telco Alarm panel.

MCH PCB 1 provides a 16-port Layer 2, non-blocking, unmanaged, low-latency 1 Gigabit Ethernet (1GigE) switch fabric for base channel connectivity. The base channel fabric supports up to twelve AdvancedMCs, two front panel RJ-45 SFP uplink ports and one fabric update channel port.

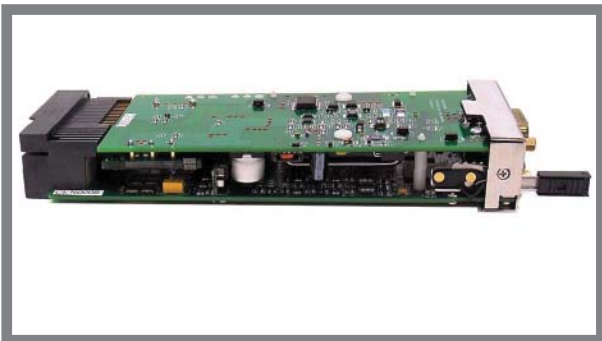

POWER MODULES

The MicroTCA Power Module serves as the interface between its MicroTCA system and the system power source and provides the following main functions:

- Accepts and conditions input power
- Converts and distributes power to MicroTCA Carrier Hub (MCH), AdvancedMC and Cooling Unit (CU)
- Monitors power, protects against faults and limits power consumption
- Works with MicroTCA Carrier Hub (MCH) to control and manage power

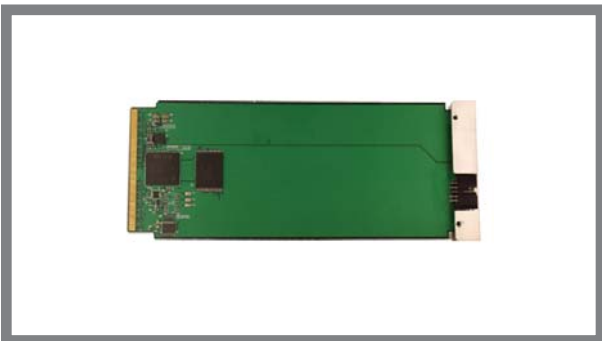

J-TAG SWITCH MODULE (JSM)

- Provides innovative diagnostic testing for programming FPGAs and HDLs, loading test vectors, software upgrades, and more
- Troubleshoots design defects and diagnoses programming errors in the field
- Programmable to check datastream traffic, find the problem, and upload the fix - all remotely
- Allows software uploads and other features to be uploaded remotely
- Features 20 J-TAG testable loads and 3MB of test vectors or software/firmware uploads optional OEM
- Optional module configuration with IPMB-0

MicroTCA Cabinet Components



FEATURES

- 19" cabinet according to ETSI 300-119-3
- 44U usable height
- Size: 2125mm H, 750mm W, 300mm D
- Sheet metal design
- Door with 4-point latching system
- Cable management
- EMC shielded
- Air/water cooling
- Closed air loop
- Accomodates up to 10 MicroTCA card cages for single AdvancedMC modules
- Cooled by max five strategically placed 1U mini heat exchangers boosted by five 1U fan trays
- Power supply tray
- Other cooling options on request

The modular cabinet features a stacked arrangement of open card cages, fan trays, and heat exchangers. Without top or bottom covers, the open card cages allow air to flow through multiple stacks of MicroTCA shelves. The fan trays and heat exchangers cool the cabinet in this modular configuration. Various implementations of card cage shelves, fans, and cooling units can be configured in the cabinet.

The MicroTCA 19" cabinet is designed according to ETSI 300-119-3 with a 44U height, 750mm width, and 300mm depth. The unit accepts 10 MicroTCA single-width sub racks, accepting 120 full size modules or 240 compact modules plus power modules dissipating a total of approximately 6kW in a closed loop heat exchanger concept. MicroTCA shelves are strategically interleaved with heat exchangers and fan trays. The heat exchangers require an external chiller unit. The typical shelf temperature rise is 15C while the heat exchangers are able to provide a temperature drop of approximately 15C. This solution allows for high-density cabinet packaging and provides the following advantages: extreme low noise, EMI containment (at closed cabinet level) and maximum possible cable routing space/management.

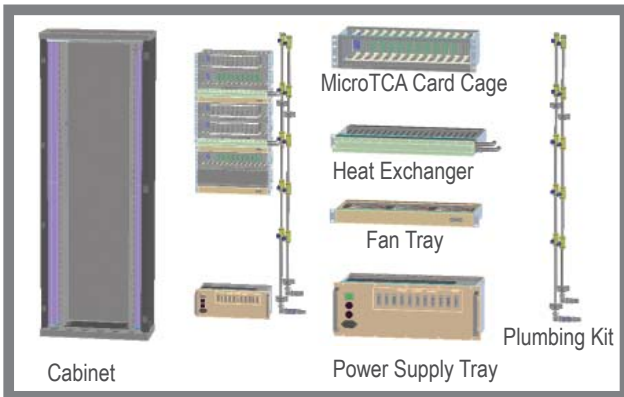

PSU TRAY

- 19" fan tray
- 1U high, 192mm deep
- 3 fans, 48VDC, 150CFM

HEAT EXCHANGER

- 19" heat exchanger
- 1U high, 192mm deep
- Optional cable tray
- Heat dissipation = 800 to 1200W

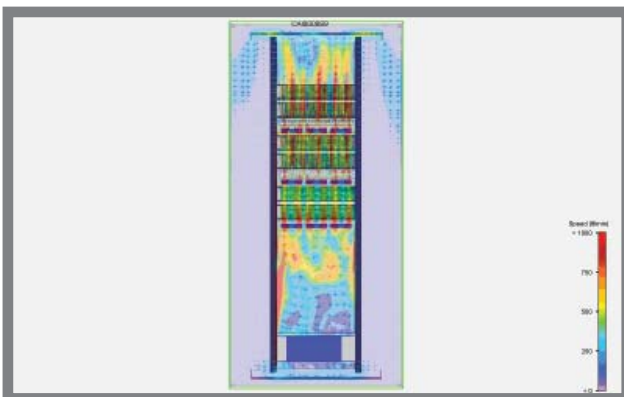

Alternative cooling option of multiple MicroTCA Shelves

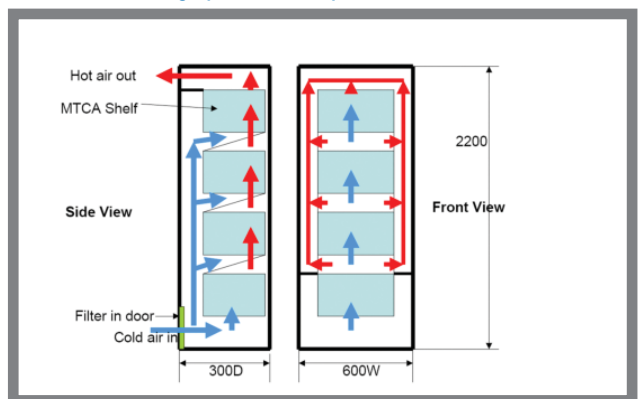

MicroTCA Accessories



AMC EXTENDER

- Complies with MicroTCA.0, AMC.1 R1.0, AMC.2 D0.96A
- Extends board outside of the card cage for easy test or de-bug
- Extends all fabric signals, 3 clock lines
- Virtually zero power consumption
- Metal frame holds board securely
- Management and payload power can be individually switch isolated
- Overall length 30.8 cm x 7.35 cm avg. width (8.55 max. width)
- Order Number: 69-MXC

The NAMC-EXT is a passive extender module, supporting all fabric connectors as defined in the AMC.x and MicroTCA specifications. The extender fits into an AMC slot like a regular AMC module. It extends the AMC card outside the card cage area, so that it can be tested or de-bugged. The NAMC-EXT provides access to the track of payload power and management power voltage. This enables the user to easily check the voltages and to measure the power consumption of the AMC under test. Test points on both the soldering and assembly side of the AMC are accessible.



AMC LOAD BOARD

- Compliant to MicroTCA.0 specification
- Compliant to PICMG AMC.0: Advanced Mezzanine Card Specification R2.0
- AdvancedMC load board with IPMI support
- Single module, full size
- Configurable load by:
 - IPMI commands
 - Selectable button on front panel
 - Incorporates JTAG interface
- Dynamic, configurable load
- Redundant operation with automatic switchover
- On-board temperature sensors
- Order Number: 69-M-LB-AMC

The AdvancedMC™ load board is dedicated for testing the cooling and power of MicroTCA systems. Single module/full size is standard with options for double modules and compact or mid sizes. The board is hot swap pluggable and has IPMI support. The load is configurable in to seven wattages: 0W, 20W, 30W, 40W, 50W, 60W and 70W. Six LEDs on the front panel indicate which power level is activated. If all LEDs are off, the power is 0W. Custom wattages and access management is available upon request.

The power level is changed by repeatedly pressing the front panel button, cycling through all power levels. Also, the power is controlled using IPMI commands (Set_FRU_LED_State / Get_FRU_LED_State) allowing each level to be controlled independently. The blink mode is also supported to set a dynamic load. Whenever the button on the front panel is pressed the local control mode is activated and all previous load settings are lost. The load board has 3 temperature sensors; one on the bottom and two on the top. These are implemented as IPMI temperature sensors and could be read through the MicroTCA Carrier Hub (MCH).

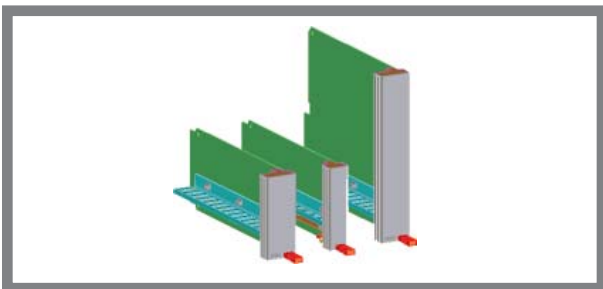

AIR BLOCK MODULES

AMC air block modules can be used to fill empty slots in the card cage and re-direct airflow. The modules block the air from the inserted slot and force it to adjacent slots. This provides 10-50% of adjustable redirected airflow. The units come in single/mid, single/full or double/full sizes.

MicroTCA Handles/Panels & Components



Module handle



Light pipe



Light pipe bracket



Light pipe bracket

MicroTCA HANDLES/PANELS

- Ergonomic design, grooves for easy handling
- Die cast construction for robust performance
- Positive detent at three distinct positions
- Fits all current microswitch locations
- Custom designs and colors available
- Additional space for customer logo on top
- Logo integrated in die-cast is possible
- Extruded panel has improved aesthetics
- Machined or stamped panel cut-outs, tight radiuses

Elma offers standard and customized MicroTCA handles and front panels. With Elma's superior quality and precision milling, even the toughest of tolerances can be achieved. Other services include logo integration, silk screening, overlays, custom cut-outs and more.

OTHER MicroTCA COMPONENTS

- Extrusions
- Tapped Strips
- Card Guides
- ESD Clips
- Contact Elma for details

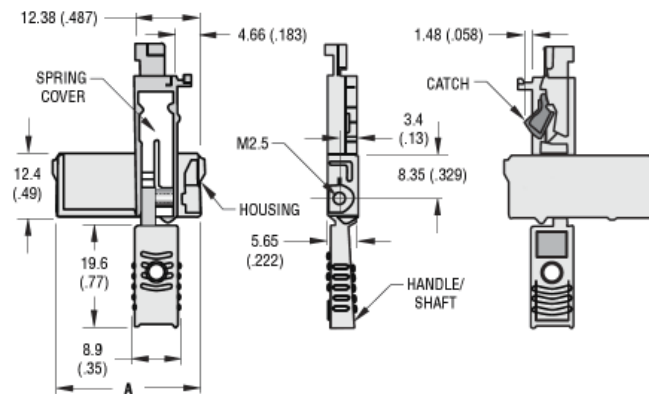

Order Information

Model Number	Description
CAE023555	AMC Handle Module, Mid Size 4HP
CAE019780	AMC Handle Module, Full Size 6HP
CAE023887	AMC Light Pipe for Handle Module
CAE027492	AMC Top Module with 2 LED Light Pipe, Mid Size 4HP
CAE027493	AMC Top Module with 2 LED Light Pipe, Full Size 6HP

MicroTCA Order Key

11M														
32M	1	2	3	4	5	6	7	8	9	10	11	12	13	14
39M														

1,2) Num. of AMC Slots
• Examp.: 01 = 1, 10 = 10

3) Module Width
• S = Single Module
• D = Double Module
• Z = Combination
• X = Not installed

4) Module Height (Pitch)
• 3 = 3 HP (Compact)
• 4 = 4 HP (Mid)
• 6 = 6 HP (Full)
• Z = Combination

5) Fabric Topology
• H = Mesh
• J = Redundant Mesh
• K = Single Star
• L = Dual Star
• N = Non Redundant
• X = Not installed
• Z = Custom

6) Height
• 1 = 1U
• 2 = 2.5U
• 3 = 3U
• 4 = 4U
• 5 = 5U
• 6 = 6U
• 7 = 7U
• 8 = 8U

7) Width
• 8 = 84T
• 7 = 87T
• 6 = 63T
• 3 = 36T
• E = ETSI

8) Depth
• 2 = 200mm-299mm
• 3 = 300mm-399mm

9) Card Orientation
• V = Vertical (Default STD)
• H = Horizontal or custom

10) PSU Input
• C = 90-230VAC (Fixed)
• H = 48VDC plug in
• M = Dual 48VDC plug in
• P = 90-230VAC(2 x HS, N+1)
• X = No PSU
• Y = 24 V Plug in
• Z = Dual 24V plug in

11) PSU Output
(Note: Not all PSU combinations available)
• 2 = 200-299 watt
• 3 = 300-399 watt
• 4 = 400-499 watt
• 5 = 500-599 watt
• X = Not installed

12) MCH
• S = 1 x Plug in
• D = 2 x Plug in
• X = Not installed

13) JSM
• Y = Installed
• X = Not installed

13) Cooling
• P = Push cooling
• R = Redundant Push-Pull
• X = Not installed

* Note 1: 1x MCH supports 12 AMC slots

** Note 2: All slot counts are based on total number of available AMC slots (single, double or single stacked).

MicroTCA Reference

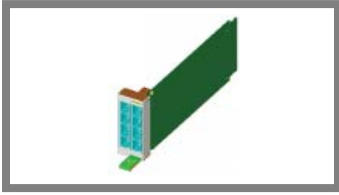

Single Module, Full Size
 Size: 73.8 x 28.95 x 181.5 mm
 Power: Up to 48W



Single Module, Compact/Mid Size
 Size: 73.8 x 13.88 x 181.5 mm
 73.8 x 18.96 x 181.5 mm
 Power: Up to 24/30W

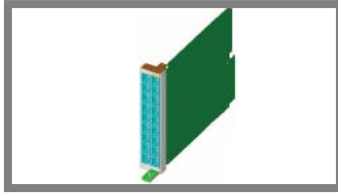

Double Module, Full Size
 Size: 148.8 x 28.95 x 181.5 mm
 Power: Up to 80W

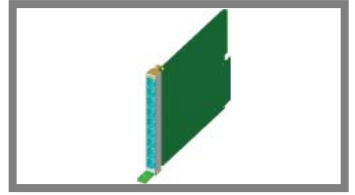

Double Module, Compact/Mid Size
 Size: 148.8 x 13.88 x 181.5 mm
 148.8 x 18.96 x 181.5 mm
 Power: Up to 48W/60W

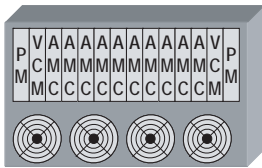

Single Shelf

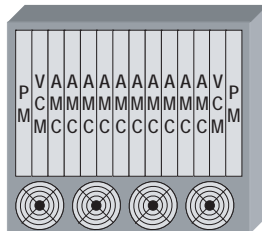

Tall Shelf

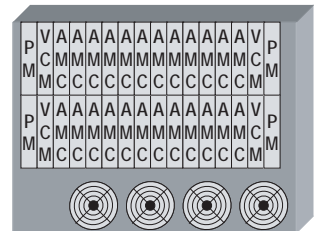

Two Tier Shelf

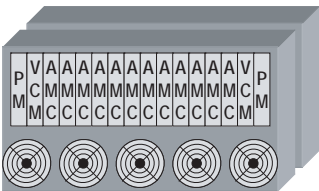

Back-to-Back Shelf

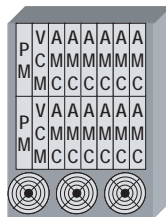

Cube Shelf



Pico Shelf

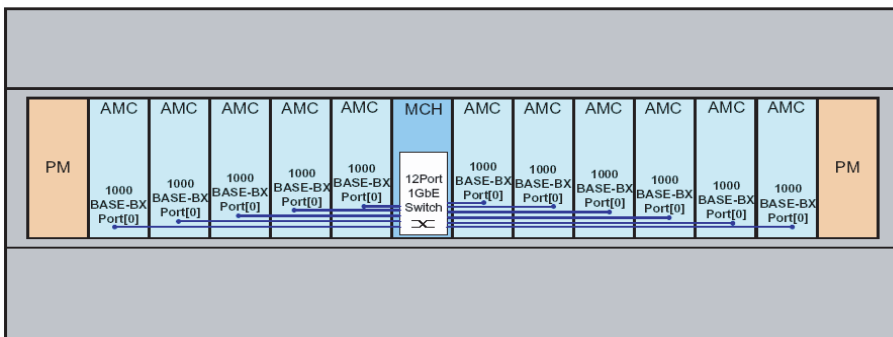

Centralized MicroTCA Carrier Hub (MCH) Switch Model

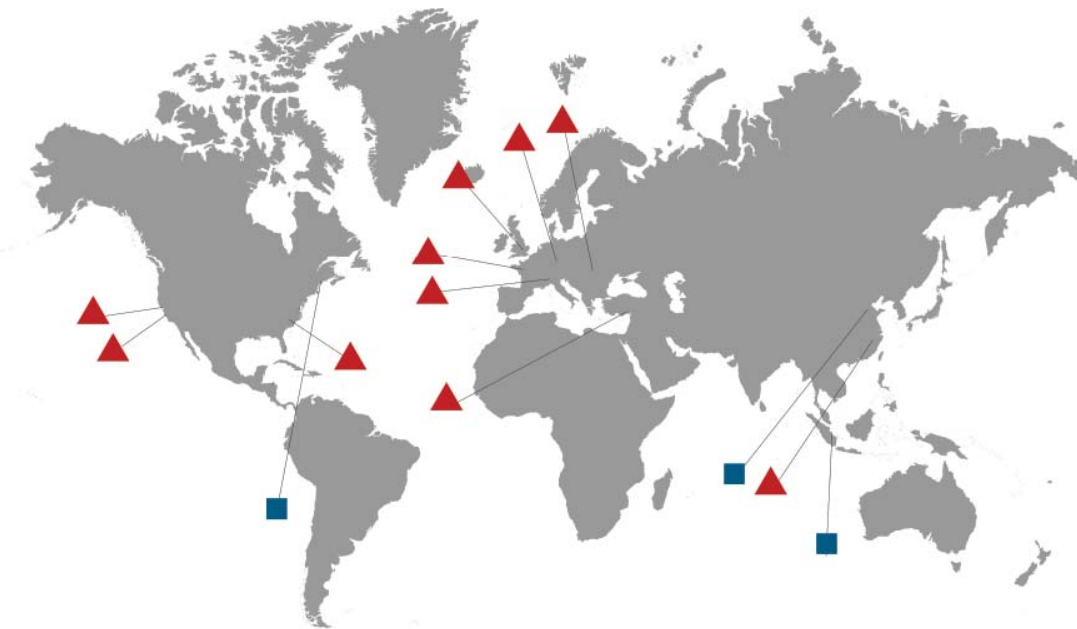

 Elma Sales Office

 Elma Production/Assembly/Sales

UNITED STATES, ELMA ELECTRONIC

Elma Electronic US Headquarters
44350 Grimmer Blvd.
Fremont, CA 94538
Phone: (510) 656-3400
Fax: (510) 656-3783
sales@elma.com
www.elma.com

ACT/Technico
760 Veterans Circle
Warminster, PA 18974
Phone: (215) 956-1200
Fax: (215) 956-1201
sales@acttechnico.com
www.acttechnico.com

ELMA BUSTRONIC

Elma Bustronic Headquarters
44350 Grimmer Blvd.
Fremont, CA 94538
Phone: (510) 490-7388
Fax: (510) 490-1853
sales@elmabustronic.com
www.elmabustronic.com

ELMA ELECTRONIC/OPTIMA

Elma Electronic/Optima EPS
2166 Mountain Industrial Blvd.
Tucker, GA 30084
Phone: (770) 496-4000
Fax: (770) 496-4041
sales@elma.com
www.elma.com

SWITZERLAND

Elma Electronic AG
Hofstrasse 93, Postfach
620 Wetzikon
Phone: +41 44 933 41 11
Fax CH: +41 44 933 42 15
Fax Inter: +41 44 932 38 12
sales@elma.ch
www.elma.com

CHINA

Elma Electronic China
8F, 355, Fu Te Road (West 1)
Wai Gao Qiao Free Trade Zone
Pudong District, Shanghai, 200131, China
Phone: +86 21 5866 5908
Fax: +86 21 5866 5918
sales@elmachina.com
www.elma.com

GERMANY

Elma Trenew Electronic GmbH
Stuttgarter Strasse 11
75179 Pforzheim
Phone: +49 7231 97 340
Fax: +49 7231 97 3497
info@elma.de
www.elma.com

ASIA PACIFIC

Elma Asia Pacific Pte. Ltd.
115-A Commonwealth Drive
#03-14 Tanglin Halt Industrial Estate
Singapore 149596
Phone: +65 6479 8552
Fax: +65 6479 8662
sales.elmaap@elma.com
www.elma.com

UNITED KINGDOM

Elma Electronic UK Ltd
Solutions House, Fraser Road
Priory Business Park, Bedford
MK44 3BF
UK
Phone: +44 (0)1234 838822
Fax: +44 (0)1234 761335
sales@elma-electronic.co.uk

ISRAEL

Elma Electronic Israel Ltd.
34, Modi'in St.
IL-I.Z. Sgula Petach Tikva 49271
Phone: +972 3 930 5025
Fax: +972 3 931 3134
sales@elma.co.il
www.elma.com

FRANCE

Elma Electronic France SASU
ZA du Buisson Rond
38460 Villemoirieu
Phone: +33 4 37 06 21 10
Fax: +33 4 37 06 21 19
sales@elma-electronic.fr
www.elma.com

ROMANIA

Elma Electronic SRL
Str. Maltopol Nr.16
011048 Bucuresti, Romania
Phone +4021 310 7998
Fax +4021 310 7992
info@elma.ro
www.elma.com