



Compact Case 20

THE BEST IN ELECTRONIC PACKAGING

SYSTEM SOLUTIONS
ENCLOSURES & COMPONENTS
ROTARY SWITCHES

THE BEST IN ELECTRONIC PACKAGING

The eye collaborates – appealing visual appearance makes work more enjoyable and therefore more efficient. The same applies to enclosures and components. Wherever you use precision electronics: The [Compact Case 20](#) design enclosure from Elma packages them up to perfection.

Variable application

The [Compact Case 20](#) comes across as a flexible, robust and high-quality aluminum enclosure for measuring devices as well as control and service applications. It is suitable for both stationary and mobile use. It ensures reliable function – in the laboratory, in medical equipment and audio applications as well as in tough environments.

Design enclosure with service option

Your [Compact Case 20](#) is quick to assemble, the front panel easy to equip. All electronics can be very easily installed – even from above. Let us do the work for you: On request, you receive your [Compact Case 20](#) with a custom design. We shape and refine the front panel – the calling card of your enclosure. Additionally, we install customer-specific components such as display, control elements, switches, etc. On request, we can even integrate the electronics for you.

Individual and cost-conscious

The [Compact Case 20](#) is available in three designs and four sizes. Scalable in terms of depth, it offers perfectly adapted internal and external dimensions. For increased loads, we can supply your enclosure in the robust rugged version. So on the one hand the Elma [Compact Case 20](#) gives you an attractive enclosure for your electronics. While on the other, you benefit from your custom solution – clever, cost-conscious and ideally configured.



THE FLEXIBLE ENCLOSURE SOLUTION

Select your [Compact Case 20](#):

- › as a basic enclosure – simple and practical
- › with 2 plastic covers in PC/ABS* – for elevated requirements
- › with 4 rugged covers in elastomers – for heavy loads

Sizes

Four versions in height and width are available:

- › 130 x 60 mm
- › 170 x 90 mm
- › 240 x 120 mm
- › 300 x 150 mm

You can choose the depth: from 150 to 300 mm – in steps of 10 mm.

Colors

Your [Compact Case 20](#) is available in aluminum, silver with black anodized side wall profiles. Please contact your Elma representative about customer-specific coloring.

Design

Combine intuitive operation with attractive design:

- › Printed front panel
- › Displays
- › Touch function
- › Switches
- › LEDs

Our specialists will gladly assist you.

EMC

The [Compact Case 20](#) offers conductively connected enclosure parts without additional seals.

Interior

As a flexible enclosure solution, the [Compact Case 20](#) enables the installation of a wide range of customer-specific components: on the bottom plate as well as on the front and rear panel. Do you need support? We are there for you: engineering, testing, integration and assembly are among our core competences.

* PC: polycarbonate
ABS: acrylonitrile butadiene styrene

SIMPLY CLEVER

Its clever design makes the enclosure solution [Compact Case 20](#) your flexible partner for everyday electronics work: among other things, for measuring and testing equipment.

The motto is "Keep it smart and simple":

- › Clear structure
- › Practical variants
- › Just one type and size of screw
- › Attractive price/performance ratio
- › Customized service

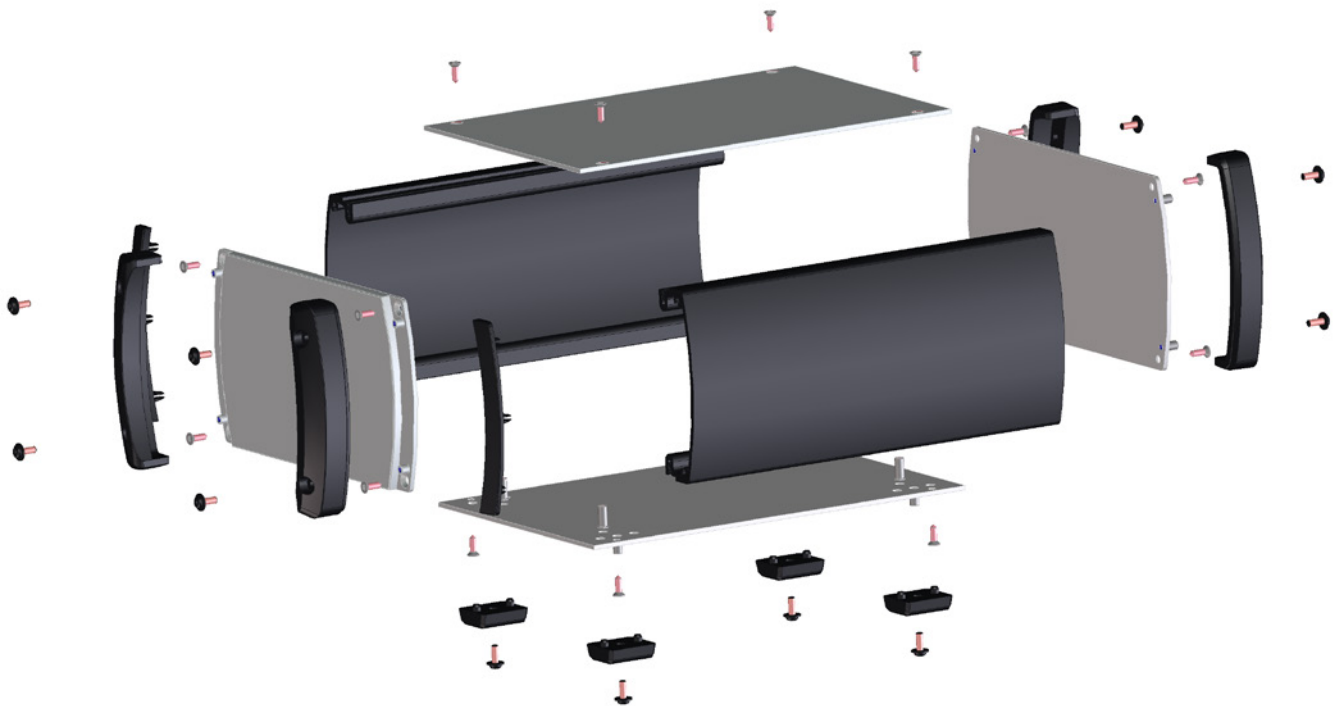

HIGH-QUALITY AND FLEXIBLE

The Compact Case 20 impresses with high-quality finish and clear design.

Standard

- › Side wall profiles: aluminum, black anodized, untreated cut edges
- › Bottom/cover plate: clear anodized aluminum, 2 mm, untreated cut edges
- › Rear panel: clear anodized aluminum, 2 mm, untreated cut edges
- › Front panel: clear anodized aluminum, 6 mm, untreated cut edges
- › Feet: elastomers, NBR 80 Shore, RAL 9005
- › Basic EMC level: conductively connected enclosure parts
- › Assembly option: directly onto the bottom plate with 4 bushes

Elevated requirements

- › including plastic covers made from PC/ABS* in RAL 9005 for the front panel

High load

- › including rugged covers made from elastomers, NBR 80 Shore in RAL 9005 for front/rear panel

Our service

- › Engineering
- › Design and printing of the enclosure parts
- › Finishing of the front/rear panel to requirements
- › Integration of customer-specific components
- › Assembly

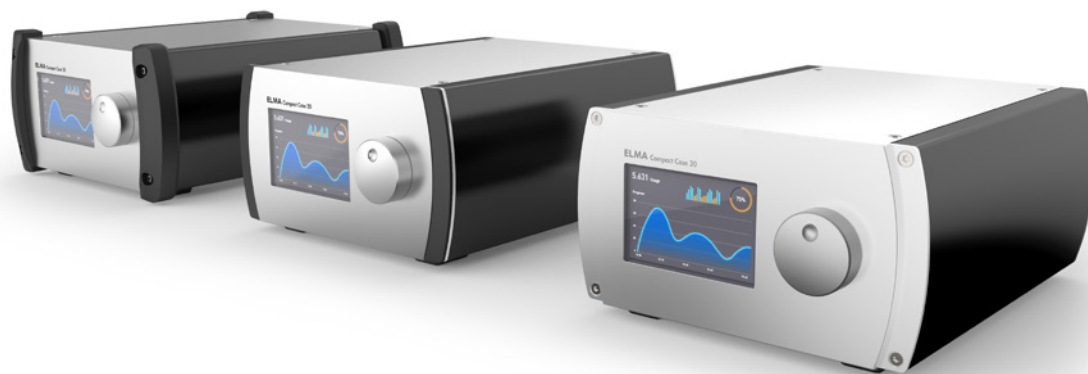

* PC: polycarbonate
ABS: acrylonitrile butadiene styrene

PRECISE IN FORM

Choose your design enclosure from Elma as you need it – the perfect size for every application. The four basic sizes can additionally be scaled in depth: from a minimum of 150 mm to a maximum of 300 mm in steps of 10 mm.



Compact Case 20 size XS
W x H x D: 130 x 60 x 150 - 300 mm



Compact Case 20 size S
W x H x D: 170 x 90 x 150 - 300 mm



Compact Case 20 size M
W x H x D: 240 x 120 x 150 - 300 mm



Compact Case 20 size L
W x H x D: 300 x 150x 150 - 300 mm

YOUR ALTERNATIVES

The *Compact Case 20* is not the right solution for your enclosure? Check out alternative Elma design enclosures:



Design enclosure iD-Box 16

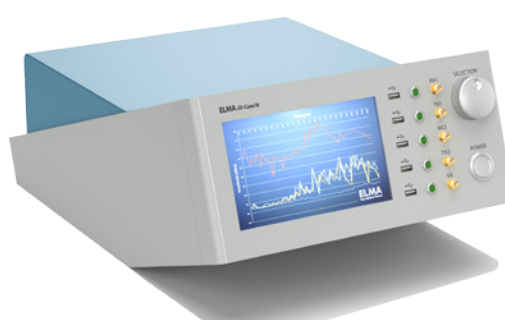

Design enclosure iD-Case 18

YOUR SOLUTION PARTNER

Elma Electronic AG develops and produces high-performance electronics and suitable enclosures from single components to entire systems for industry, railway technology and medical equipment. With over 100 employees in Switzerland alone, we offer innovative, high-quality products, customer-specific solutions and engineering services.

Our key strengths include a high level of development competence and an extensive electronics portfolio. From rotary switches and other electromechanical components to backplanes, computer and storage solutions, power supply units and electronic packaging, all the way to fully integrated systems. On this basis, we are in a position to develop new and trendsetting solutions quickly and safely – in top quality and convincing design, as prototypes or ready for series production.

We are listed on the Swiss Stock Exchange and represented around the world: The Elma Group – Elma Europe, Elma America and Elma Asia – includes subsidiaries in ten countries and a global sales network. In the customer's interest, we co-operate with leading technology providers in the sector and are ourselves regularly approached for advice. Everything from a single source, proven standards, outstanding solutions: Choose Elma Electronic AG.





**Elma Electronic AG,
Switzerland**

Hofstrasse 93
CH-8620 Wetzikon
T: +41 44 933 41 11
F: +41 44 933 42 15
sales@elma.ch

**Elma Electronic GmbH,
Germany**

Stuttgarter Strasse 11
D-75179 Pforzheim
T: +49 7231 97 34 0
F: +49 7231 97 34 97
info@elma.de

Elma Electronic France SA

ZA du Buisson Rond
F-38460 Villemoirieu
T: +33 4 37 06 21 10
F: +33 4 37 06 21 19
sales@elma-electronic.fr

Elma Electronic UK Ltd.

Solutions House
Priory Business Park
Fraser Road
Bedford MK44 3BF
Great Britain
T: +44 1234 838822
F: +44 1234 836650
sales@elma.co.uk

Elma Electronic Romania SRL

Chisoda, DN 59 km8 + 550m
RO-307221 Judetul Timis
T: +40 374 480 400
F: +40 256 249 820
sales@elma.ch

Elma Electronic Israel Ltd.

34, Modi'in St., I.Z.Sgula
IL-49271 Petach-Tikva
T: +972 3 930 50 25
F: +972 3 931 31 34
sales@elma.co.il

Elma Electronic Inc., USA

44350 S. Grimmer Blvd
Fremont, CA 94538, USA
T: +1 510 656 3400
F: +1 510 656 3783
sales@elma.com

Optima Stantron, USA

1775 MacLeod Drive
Lawrenceville, GA 30043, USA
T: +1 770 496 4000
F: +1 770 496 4026
sales@elma.com

**Elma Electronic Private Ltd.,
India**

Green Arch
3rd Phase 1st Main
J.P. Nagar
Bangalore 560078
sales@elma.com

**Elma Electronic Technology
(Shanghai) CO., LTD., China**

No. 11 Building, No198
Chang Jian Road,
Bao Shan District
CN-200949 Shanghai
T: +86 21 5866 5908
F: +86 21 5866 5918
sales@elmachina.com

**Elma Asia Pacific Pte. Ltd.,
Singapore**

8 Ubi Road 2
07-14 Zervex Building
SG-408538 Singapore
T: +65 6479 8552
F: +65 6479 8662
sales.elmaap@elma.com

Your local solution partner